

Industrial Electronics Technician

Exam preparation Documentation

Part 2

2026

Test Taker first and last name:

Test Taker number:

Test Taker company:



German American
Chambers of Commerce
Deutsch-Amerikanische
Handelskammern

**German American Chamber of Commerce
of the Midwest, Inc.**

150 North Michigan Avenue, 35th Floor
Chicago, Illinois 60601

Phone: +1 (312) 644-2662 | Fax: +1 (312) 644-0738
www.gaccmidwest.org

General notes

In the Part 2 examination, the test taker must carry out a complex work assignment.

The training company is to provide the testing equipment listed in the "Standard material staging list" and in this YELLOW preparation document for the practical exam assignment and technical discussion. This test equipment and both documents must be given to the test taker within 2-3 months of the test date to ensure that the test taker can check the test equipment for completeness and functionality.

The test taker must bring this documentation and the "Standard material staging list" to the practical examination.

The trainer/company must inform the test taker that work clothing must correspond to the accident prevention regulations.

The training company must ensure that the test taker has received safety training that correspond to the valid work regulations

Test preparation important note:

For the Part 2 exam, this YELLOW preparation documentation contains a control program.

The test taker has to prepare this control program on a memory device that works with the automation system and bring it to the test. Depending on the problem, the test taker must transfer the control program that was brought from the memory device to the automation system and be able to put it into operation.

The documents have been created to be as neutral as possible and must be adapted as necessary for the actual components used.

The following must be provided on the title page of this YELLOW preparation documentation

- The test-taker number assigned (at test)
- First and last name of the test taker

The standard provisioning documents and preparation material can be accessed and downloaded from the ICATT resource page

This test was resolved by a committee composed of members from different regions in the United States. It has been developed for implementation and acceptance of examinations as part of training examinations. Neither the test nor products based on it are intended for reproduction or free trade.

Final Examination Overview - ICATT Industrial Electronics Technician			
Final examination: Part 1 Weighting: 40 %		Final examination: Part 2 Weighting: 60 %	
Areas of examination		Areas of examination	
<p>Practical task with professional, situation-based discussions</p> <p>Weighting: 50 % Total time permitted: 6.5 h</p>	<p>Written examination</p> <p>Weighting: 50 % Total time permitted: 1 h 30 min</p>	<p>Practical task with professional, situation-based discussions</p> <p>Weighting: 50 % Total time: 14 h</p>	<p>Written examination</p> <p>– Work planning – Functional analysis – OSHA and Workers Rights</p> <p>Weighting: 50 % Total time permitted: 4 h 15 min</p>
<p>– Planning* Weighting: 20 % Time suggested: 30 min</p> <p>– Execution including tech discussion Weighting: 40 % Time suggested: 4 h</p> <p>–Commissioning Weighting: 35 % Time suggested: 2 h</p>	<p>– Part A (50%): 23 multiple choice questions 3 of which can be deselected</p> <p>– Part B (50%): 8 short answer questions No deselection possible</p>	<p>– Preparation for the practical task Time allotted: 8 h In company</p> <p>– Execution of the practical task Time allotted: 6 h At exam site</p> <p>Including technical discussion Time allotted: 20 min</p>	<p>– Work Planning Time permitted: 105 min Weighting: 40 %</p> <p>Part A (50%): 28 multiple choice questions – 3 of which can be deselected</p> <p>Part B (50%): 8 short answer questions No deselection possible</p>
<p>Professional, situation-based discussions</p> <p>Weighting: 5 % Time permitted: 10 min</p> <ul style="list-style-type: none"> – The duration of the discussions is included in the examination time. – The discussions can last up to 10 min within the scope of the examination and can be held continuously or in stages. 		<p>Phases:</p> <ul style="list-style-type: none"> – Information – Planning – Execution – Review <p>The practical task is assessed by means of:</p> <ul style="list-style-type: none"> – Task-specific documents – Professional, situation-based discussions – Observations by the board of examiners 	<p>– Functional analysis Time permitted: 105 min Weighting: 40 %</p> <p>Part A (50%): 28 multiple choice questions 3 of which can be deselected</p> <p>Part B (50%): 8 short answer questions No deselection possible</p>
			<p>– OSHA and Workers Rights</p> <p>Time permitted: 45 min Weighting: 20 %</p> <p>20 multiple choice questions 5 of which can be deselected</p> <p>4 short answer questions 1 of which can be deselected</p>

*The planning phase takes place after the written assignments. If the planning time is exceeded or not used in full, the relevant deviation is compensated for in the execution and review phases to ensure that the total permitted time of 6 h 30 min is not exceeded.

AHK-USA Chicago

Final Examination Part 2 - 2026

Work Task
General

Industrial Electronics Technician

Prior to the day of the exam, the test taker should be allotted approximately 8 hours to complete the control task in this booklet. E.g. create circuit diagrams, bills of materials, install the switching devices on the test frame, wire the circuit, program the automation system, commission the system and test it.

On the day of the exam, the test taker will only have 6 hours to implement an extension of / addition to the electrically engineered system under the supervision of the exam board.

The following tasks should be completed **within** the 8-hour period prior to testing:

- Compiling the materials listed in the booklet "Standard provision documents for the company providing training" and determining their prices.
- Setup of the assembly plate (cable duct, top-hat rails and plug-in card holder)
- Setup of the process simulation board with functional test
- Connecting the 18-pin connecting line to -X3
- Establishing the connection between -X4 and the automation system

Preparatory documents included in this booklet:

- Setup of the process simulation board
- List of consumables for the preparation and implementation
- General information
- Description of the work task
- Work plan
- Setup suggestion for the assembly plate
- Setup suggestion for the PB controller
- Terminal diagram
- Plug-in card holder
- Circuit diagram: Main circuit
- Circuit diagram: Control circuit
- Connection diagram: Input module
- Connection diagram: Output module
- Assignment list
- Program documentation
- Commissioning protocol -testing the system for operation (in accordance with DIN VDE 0100-600, or other identified electrical standard)

Item No.	Qty.	Designation	Type/Value/Standard	Comment	Price
1	1	Assembly plate	600 mm × 600 mm	e.g. perforated plate	
2	2.5 m	DIN mounting rail	DIN EN 60715		
3	4 m	Wiring duct; slotted	e.g. $H = 40$; $B = 25$		
4	47	Feed-through terminal	2.5 mm ² ; gy		
5	6	Feed-through terminal	2.5 mm ² ; gn-ye		
6	2	Label 1 - 50		For Item Nos. 4 and 5	
7	2	End plate		For Item Nos. 4 and 5	
8	4	Fastener		For Item Nos. 4 and 5	
9	4	Connecting bridge	2-pin	For Item Nos. 4 and 5	
10	2	Connecting bridge	6-pin	For Item Nos. 4 and 5	
11	23	Double layer terminal strip	2.5 mm ² ; gy		
12	2	Double layer terminal strip	2.5 mm ² ; gn-ye		
13	2	Label 1 - 50		For Item Nos. 11 and 12	
14	2	End plate		For Item Nos. 11 and 12	
15	4	Fastener		For Item Nos. 11 and 12	
16	4	Connecting bridge	2-pin	For Item Nos. 11 and 12	
17	2	Connecting bridge	10-pin ("endless"; divisible)	For Item Nos. 11 and 12	
18	1	Power supply unit	230 V AC/24 V DC ≥ 2.5 A		
19	1	Circuit breaker	C4 A; 1-pin	For Item No. 18 (secondary-side)	
20	4	Circuit breaker	B16 A; 1-pin		
21	2	D01 fuse block with screw cap	3-pin		
22	2	D01 fuse block with screw cap	1-pin		
23	13	D01 fuse cartridge with corresponding screw-in insert	3 × 16 A; 6 × 10 A; 2 × 6 A; 2 × 2 A		
24	1	Residual-current device (RCD)	25 A/30 mA; 4-pin	Also suitable for 2-pin connection (L-N)	
25	3	Motor protection switch with auxiliary contacts	2.2 A–3.2 A; 1 NO + 1 NC		
26	2	Motor protection relay with auxiliary contacts	2.2 A–3.2 A; 1 NO + 1 NC		
AHK	Final Examination Part 1 and Part 2		Standard provision documents for the training company Standard material provision list		
	Industrial Electronics Technician				

Item No.	Qty.	Designation	Type/Value/Standard	Comment	Price
27	5	Contactors with quenching circuit	24 V DC; 3 H + 2 NO + 2 NC		
28	1	Protective contact socket for assembly on a top-hat rail	16 A		
29	2	Empty housing for 4 command and display elements with cable clamp and connecting element		For Item Nos. 30 and 39	
30	2	Built-in selector switch	Toggle switch 0-1	For Item No. 29	
31	2	Built-in selector switch	Toggle switch 1-0-1	For Item No. 29	
32	2	Built-in button	2 × bk	For Item No. 29	
33	5	Built-in illuminated button	5 × wh	For Item No. 29; also to be used as indicator lamp	
34	2	Built-in signal lamp	2 × ye	For Item No. 29	
35	5	Dummy plug		For Item No. 29	
36	8	Contact element	1 NO	For Item Nos. 30 and 33	
37	4	Contact element	1 NC	For Item Nos. 30 and 33	
38	5	LED element	24 V	For Item Nos. 33 and 34	
39	8	Mounting adapter		For Item Nos. 36 and 38	
40	1	PCB holder with female multipoint connector	32-pin; DIN EN 60603-2		
41	1	Connecting cable including CEE plug 16 A	H07RN-F 5 G 1.5	Approx. 3 m	
42	1.5 m	Line	Y-JZ 18 × 0.75 mm ²		
43	2	Cable clamp		For Item Nos. 41 and 42	
44	1 m	PVC single-core non-sheathed cable	H07V-K 1.5 mm ² ; gn-ye		
45	1	Protective earth terminal			
46	1	Identification label for test taker number			
47	1	Labeling material (self-adhesive) for components			
AHK	Final examination Part 1 and Part 2 Industrial Electronics Technician		Standard provision documents for the training company Standard material provision list		
			Page 5 of 31		

Material for Final Examination Part 2

Item No.	Qty.	Designation	Type/Value/Standard	Comment	Price
48a	1	Automation system with programming option; memory device for taking along a program	24 V DC power supply; 14 digital inputs; 10 digital outputs (relays); 2 analog inputs (0-10 V); 2 analog outputs (0-20 mA);	Can also be used in Final Examination Part 1.	

Material for Final Examination Part 1

Item No.	Qty.	Designation	Type/Value/Standard	Comment	Price
48b	1	Automation system with programming option; memory device for taking along a program	24 V DC power supply; 14 digital inputs; 10 digital outputs (relays);		

AHK	Final Examination Part 1 and Part 2	Standard provision documents for the training company Standard material provision list		
	Industrial Electronics Technician			

AHK

Final Examination Part 1 and Part 2

Standard provision documents for the training company
Test equipment, tools, aids

Industrial Electronics Technician

I Test equipment that every test taker needs:

1. 1 multimeter for current, voltage and resistance measurement and continuity tester with measuring lines/tips

II Tools that every test taker needs at minimum:

1. 1 set of screwdrivers for slotted screws
2. 1 set of screwdrivers for Phillips screws
3. 1 side-cutting pliers
4. 1 set of telephone pliers (bent)
5. 1 stripping tool
6. 1 crimper for wire end sleeves
7. 1 cable knife
8. 1 open-end wrench 7 mm, 8 mm

III Tools and test equipment that are needed for 1 to 5 test takers:

1. 1 VDE testing device VDE 0413 for testing the safety measures in accordance with VDE 0100-600 (insulation resistance, ground wire resistance, rotating field test, etc.)
2. 1 crimper for cable lugs 1.5 mm² to 4 mm² (as needed)

IV Aids that every test taker needs:

1. Books of tables
2. Drawing tools
3. Non-programmable, offline pocket calculator incapable of external communication
4. Folder

The work clothing and tools of the test taker must comply with the applicable accident prevention regulations. If they do not comply with the accident prevention regulations, participation in the test is not permitted.

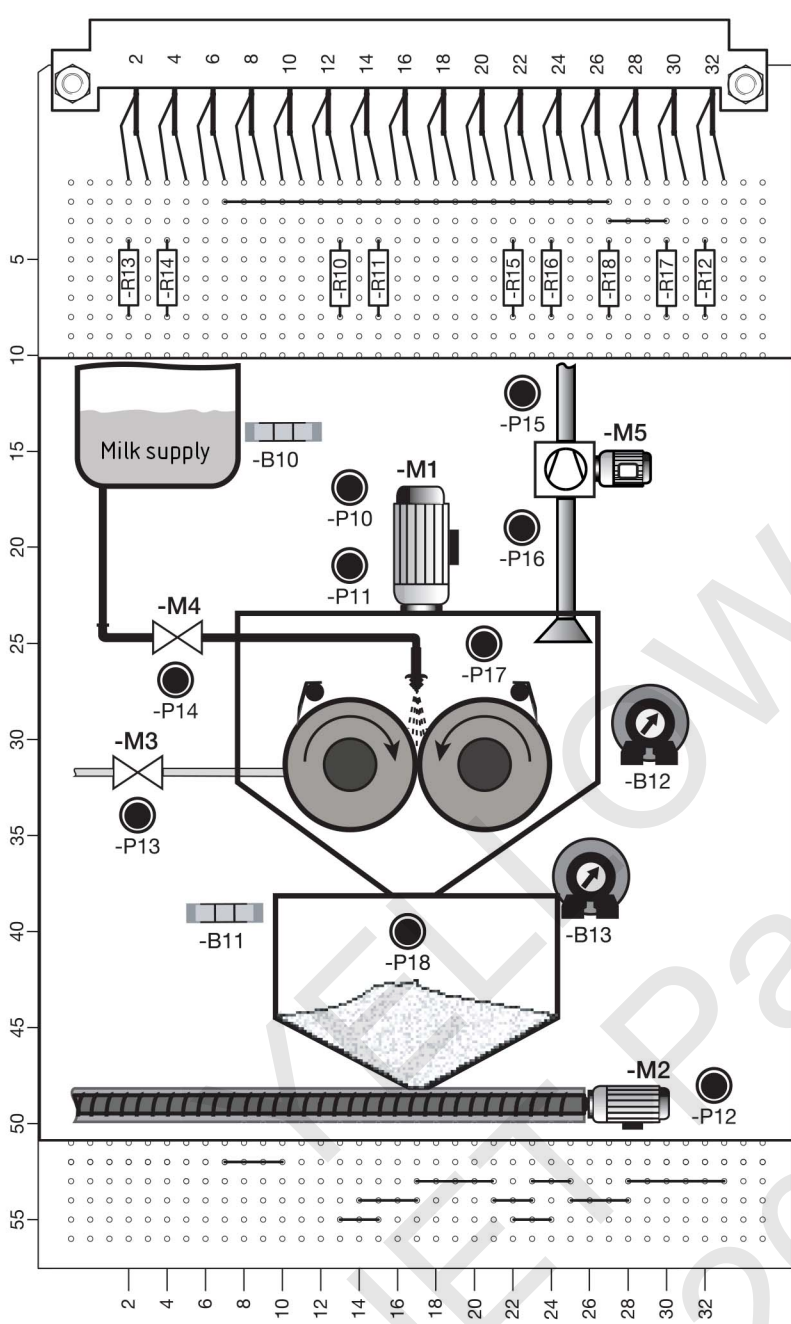

1 Connection diagram for contact strip

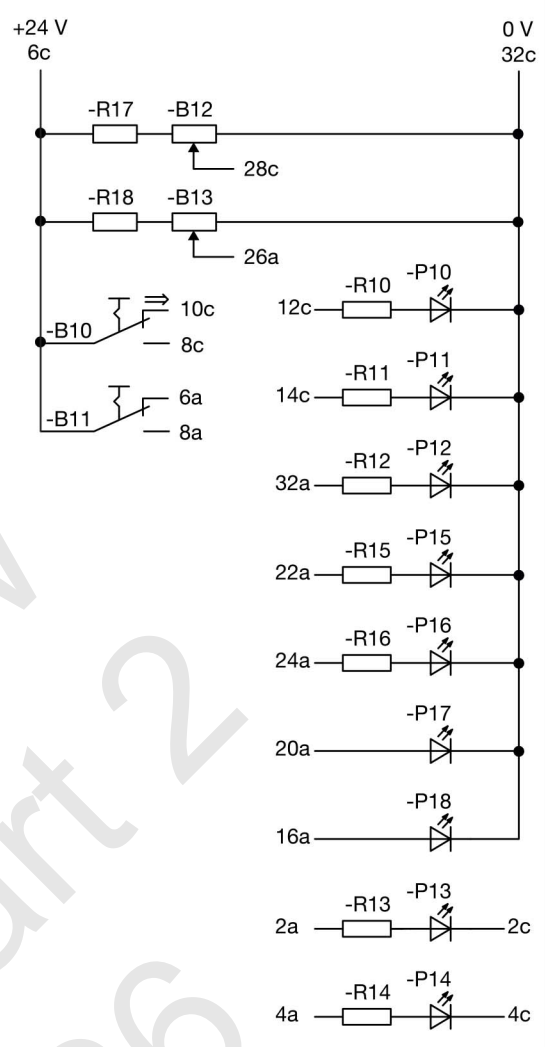

Note:
The home position of slide switches -B10 to -B11 are to be configured in accordance with the specification "Connection diagram for contact strip".

8	2	-P17, -P18	LED Ø3 mm	$I_F = 20 \text{ mA}$, 2 × ye
7	2	-R17, -R18	Resistance suitable for Item no. 5	12 kΩ
6	2	-B12, -B13	Potentiometer	10 kΩ, contact spacing 2.54
5	7	-R10 to -R16	Resistance suitable for Item no. 4	($U_B = 24 \text{ V}$)
4	7	-P10 to -P16	LED Ø3 mm	7 × gn
3	2	-B10 to -B11	Miniature slide switch	1 change pin
2			Tin-plated copper wire	
1	1	-A1/-X10	Vero board with pin header	32-pin a-c
Item no.	Qty.	Marking	Designation	Type/value/standard

AHK

Final Examination Part 2 - 2026

Work Task
Preparation for the practical tasks
Process Simulation

First and last name: _____

Test taker number: _____

Industrial Electronics Technician

2 Component side

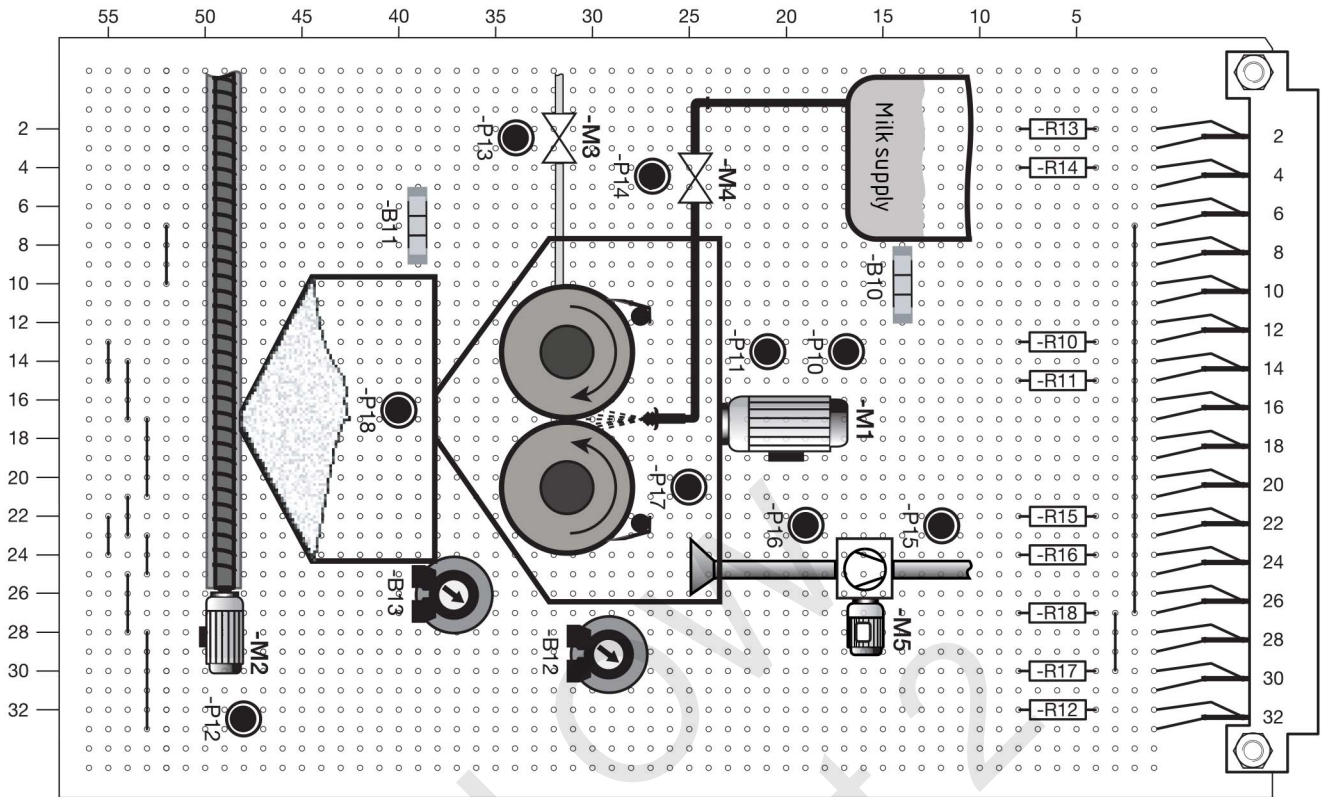

3 Conductor breaks/faults on the copper side

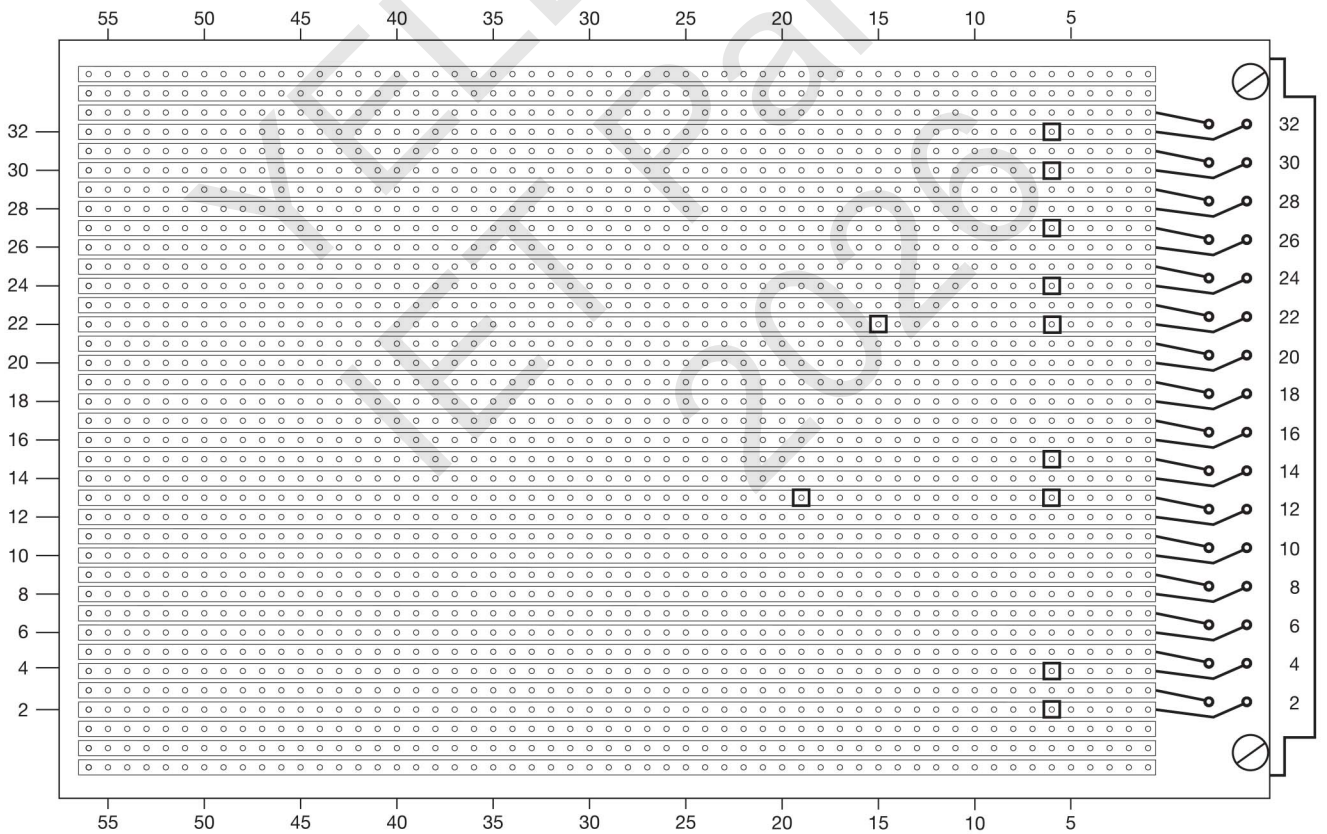

AHK

Final Examination Part 2 - 2026

First and last name:

Test taker number:

Work Task
Preparation for the practical tasks
Process Simulation

Industrial Electronics Technician

AHK-USA Chicago

Final Examination Part 2 - 2026

Work Task

Preparation of the practical task

General information

Industrial Electronics Technician

1 General information

For the "Preparation of the practical task", the material from the "Standard provision documents for the company providing training" and the provision documents in this booklet must be used. Make sure to observe the applicable standards and regulations.

The specified worksheets must be used and can be added on to if necessary, with the allocation clearly marked.

Before completing the "Preparation of the practical task", label all documents, including your internal company documentation and your self-created documentation, with your first and last name and test taker number and store them in the folder.

The functional system and the folder created from your documents, internal company documentation and/or your self-created documentation must have been submitted on the day of the test upon arrival.

2 Allotted time: 8h

3 Planning the task

Before beginning the work, you have to clarify organizational questions. Specifically, these include:

- Organization of the work (workflows, equipment, work time)
- Checking the circuit documentation (diagrams, descriptions, etc.)
- Definition of the home conditions (type of system, type of wiring, etc.)
- Procurement of the required materials
- Coordination of the work with the people involved

4 Task Implementation

The required control cabinet is simulated with a 600 mm × 600 mm assembly plate. A 5-pin 16-A-CEE plug is used for the network connection. The PB controller is connected to terminal strip -X3. The automation system is connected via terminal strip -X4. The shielded line for the detection of the analog values is connected directly to the automation system and to the plug-in card holder -X10

Terminal points for the control voltage (**except** for the PB controller (-X3)) and the control system (-X4), are routed through -X2. Terminal strip -X1 is used to connect all three-phase and AC connections. The system is simulated using the process simulation board. The process simulation board is connected by means of plug-in card holder -X10.

The main circuits must be wired completely up to terminal strip -X1. Observe the correct fuse protection for the circuits required.

Based on the documentation, install the control system properly in accordance with your customary specifications. Supplement the documentation. Create the control program for the system. The documentation for the program can be attached in the form of a standard company printout. After completion of the system in accordance with the customer order, the system is commissioned with an inspection in accordance with DIN VDE 0100-600 or other company standard, and a function check must be completed. The function test must be documented by a commissioning protocol (e.g. attached protocol), which must be brought on the day of the test.

Provide the following operating voltages for the system:

200 V/60 Hz supply voltage (3/N/PE)

24 V DC control voltage

24 V DC process simulation board

5 Inspection (commissioning)

The completed system must be inspected as described in DIN VDE 0100-600 or company standard and documented with a commissioning protocol (e.g. the accompanying report).

Check the documents to be brought on the day of the test for completeness.

6 Documentation

All documentation of the customer order (test assignment) must be brought to the test center on the day of the test in an organized folder. Furthermore, the standard provision documents, the provision documents for the company providing training, the commissioning protocol and all documents that were necessary for the "Preparation of the practical task" must be brought.

7 Test day – at the test center (system modification)

On the day of the test, bring the following to the test center:

- The remaining devices from the standard provision documents for the company providing training
- Consumables, aids, test equipment and tools in accordance with advance notification and necessary devices for changing the control program (documentation is possible in handwriting)
- The functional process simulation board
- The functional complete control system in accordance with the customer order of the preparation
- All required documentation

1 Assignment description

You are tasked with building a control cabinet with a control panel for a part of the shown system. You are to wire the main control circuits according to the customer specifications.

2 Technology diagram: Roller dryer

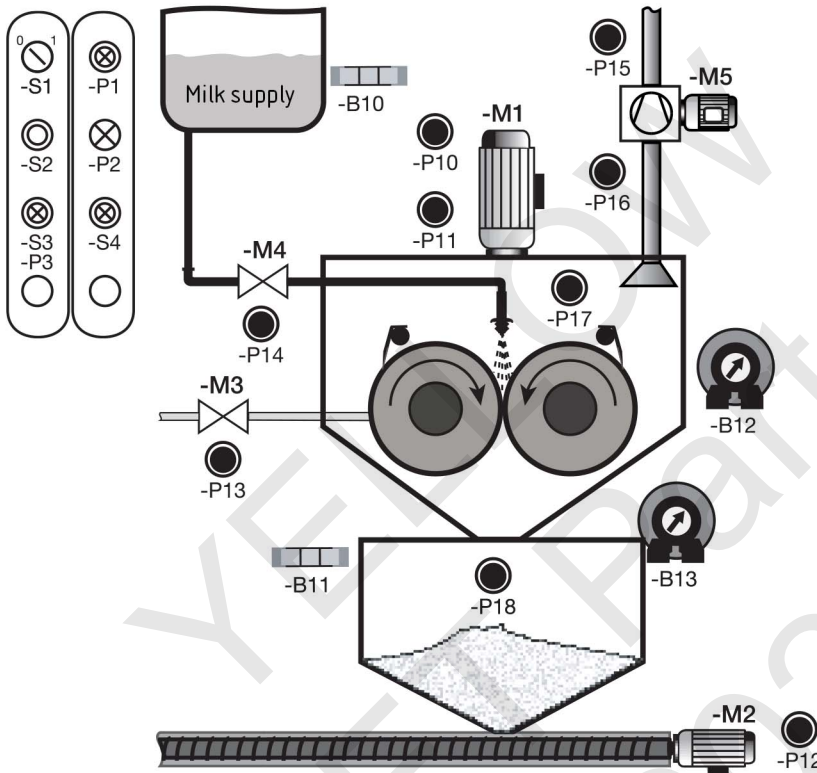

Motor Name Plate -M1:

Manufacturer	
Type	
3 ~ Mot	No.
Δ 400 V	2,5 A
0,75 kW	S 1
cos φ 0,65	
690 rpm	50 Hz
-/- V	
-/- A	
Insul. Cl. B	IP 54
19,2 kg	
VDE 0530	

Motor Name Plate -M2:

Manufacturer	
Type	
3 ~ Mot	No.
Δ 400 V	2,42 A
1,1 kW	S 1
cos φ 0,85	
2850 rpm	50 Hz
-/- V	
-/- A	
Insul. Cl. B	IP 54
9,9 kg	
VDE 0530	

Description: Process simulation

- M1 "Roller drive" motor
- M2 "Auger" motor
- M3 "-M3" solenoid valve
- M4 "-M4" solenoid valve

- B10 "Milk present" sensor, NO
- B11 "Collection container full" sensor, NO
- B12 "Roll temperature" sensor (0–10 V/0–200 °C)

- P11 "-M1" display
- P12 "-M2" display
- P13 "-M3" simulation
- P14 "-M4" simulation
- P17 "Roll temperature" display (0–20 mA/100–200 °C)

Description: Control panel

- S1 "System ON/OFF" button, NO
- S2 "Confirm fault" button, NO
- S3 "Start drying" button, NO
- S4 "Drying off" button, NC

- P1 "System on" signal lamp
- P2 "Fault" signal lamp
- P3 "Temperature > 140°C" signal lamp

AHK-USA Chicago

Final Examination Part 2 - 2026

Work Task

Preparation of the practical task
Functional Description

Industrial Electronics Technician

3 Functional description in accordance with customer order

In the home position, the milk supply is full, the collection container is empty, and the roller temperature is under 100°C.

The system is switched on or off with switch -S1. If the system is switched off, no actuator is active.

If the system is on, solenoid valve-M3 opens and steam heats the rollers. Sensor -B12 detects the temperature of the rollers. Once the roller temperature exceeds 140°C, signal lamp -P3 illuminates and the drying process can be started by pressing -S3.

If button -S3 is pressed, motor -M1 turns on and after 5 seconds the solenoid valve -M4 opens. The milk is evenly distributed on the steam-heated rollers and dried within 3/4 of a turn. The dried milk is then scraped off of the rollers with a knife and the falls as powdered milk into the collection container.

If button -S4 is pressed, or sensor -B10 is activated, or the roller temperature (-B12) drops below 140°C for more than 5 seconds, the drying process turns off, closing solenoid valve -M4 and switching off motor -M1 after 5 seconds.

Sensor -B11 is used to detect the fill level of the collection container. If sensor -B11 is activated, motor -M2 turns on. If -B11 is no longer activated, -M2 will turn off after 5 seconds.

Motor -M1 is protected by a motor protection relay. If the motor protection device trips, motor -M1 and both solenoid valves will turn off. Motor -M2 is protected by a motor protection switch. If the motor protection device trips, motor -M2 will turn off.

If the motor protection device trips, signal lamp -P2 blinks. After the motor protection relay has cooled or the motor protection switch is turned on, the fault can be confirmed with button -S2, the signal lamp -P2 goes out and the interrupted cycle can start anew.

The operating state of motor -M1 and -M2 is indicated by an auxiliary contact of the corresponding contactor on the process simulation board (-P11 and -P12). The solenoid valves -M3 and -M4 are controlled directly from an output of the automation device and are replicated on the process simulation board (-P13 and -P14). The roller temperature is continuously detected and displayed with LED -P17.

A 16 A receptacle is to be installed for maintenance work. Protection against overcurrent from ground fault by means of a GFCI.

AHK-USA Chicago

Final Examination Part 2 - 2026

Work Task
Preparation of the practical task
Work Plan

Industrial Electronics Technician

Using short sentences, describe the implementation of the present work task.

No.	Steps
	<p style="text-align: center; opacity: 0.3; font-size: 48px; transform: rotate(-30deg);">YELLOW IET Part 2 2026</p>

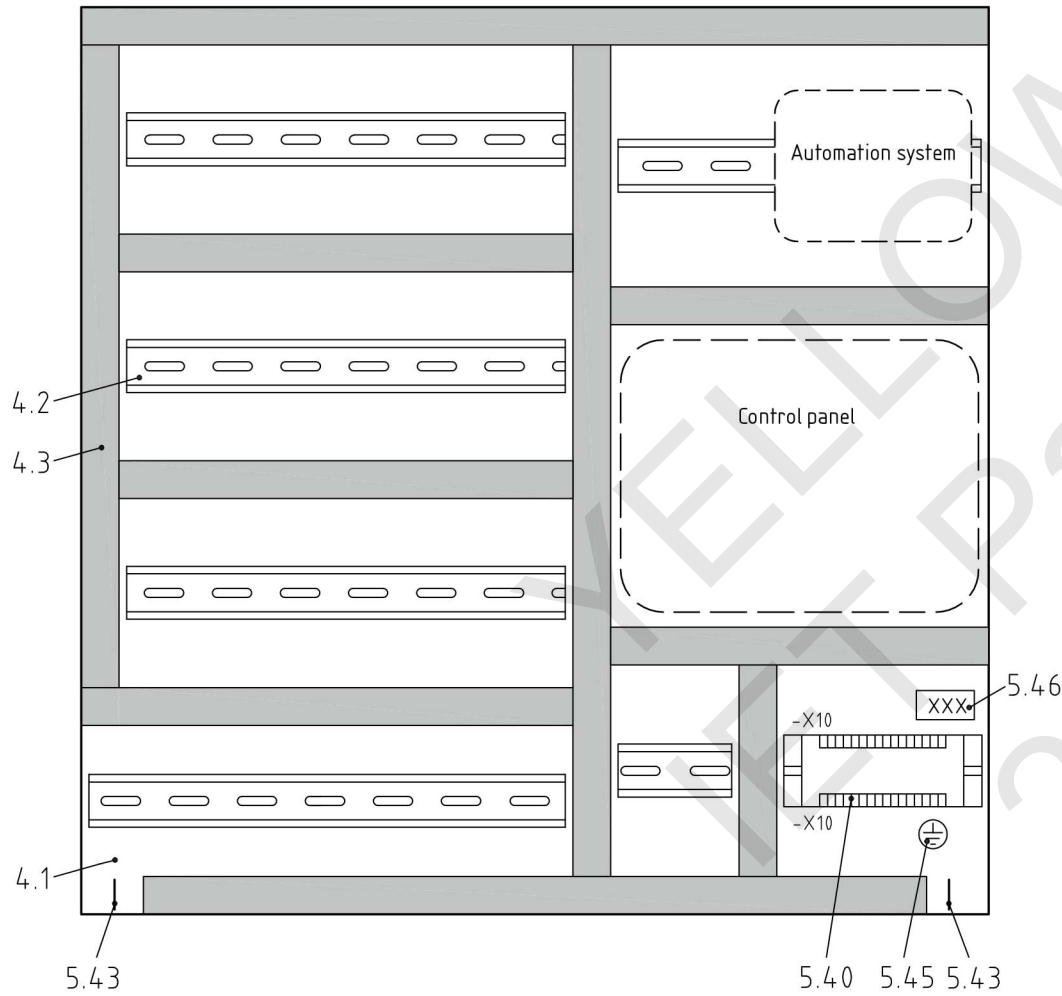

Note:
 What is shown here is standard assembly, variations are possible. You will add to these drawings when completing your preparation assignment and on exam day, so be sure to bring these documents to your exam.

The Item no. relate to the standard provision documents for the training company, pages 4, 5, and 6.

Item no.	Qty.	Designation	Type/value/standard/comment
5.46	1	Identification label for the test-taker no.	
5.45	1	Protective earth terminal	
5.43	2	Cable clamp	
5.40	1	PCB holder	
4.3		Wiring duct	slotted H = 40mm, B = 25mm
4.2		DIN mounting rail	in accordance with DIN EN 60715
4.1	1	Assembly plate	600 mm x 600 mm

Function	Objective	Terminal	Bridge	Objective
Terminal block -X1 230/400 V				
L1		1		-F1:1
		2		
L2		3		
		4		
L3		5		
		6		
N		7		
		8		-T1:2
PE		9/PE		M-Platte
		10/PE		-X2:11
		11/PE		-X3:20
		12		
		13		
		14		
		15/PE		-X4:30
		16		
		17		
		18		
		19/PE		
		20		
		21		
		22		
		23		
		24		
		25		
		26		

Function	Objective	Terminal	Bridge	Objective
Terminal block -X2 24 V DC				
L+		1		-F2:2
		2		-X3:1
		3		-X4:1
		4		-X4:2
	-X10:6c	5		
		6		
L-		7		-T1:4
		8		-X3:3
		9		-X4:3
		10		-X4:4
	-X10:32c	11		-X1:10
		12		
		13		
		14		
		15		
		16		
		17		
		18		
		19		
		20		
		21		
		22		
		23		
		24		
		25		
		26		

Function	Objective	Terminal	Bridge	Objective
Terminal block -X3 Operating elements				
1L+		1		-X2:2
		2		
1L-		3		-X2:8
		4		
		5		
		6		
		7		
		8		
		9		
		10		
		11		
		12		
		13		
		14		
		15		
		16		
		17		
		18		
		19/PE		
		20/PE		-X1:11

Function	Objective	Terminal	Bridge	Objective
Terminal block -X4 Automation system				
2L+	-X2:3	1		AS
3L+	-X2:4	2		E/A
2L-	-X2:9	3		AS
3L-	-X2:10	4		E/A
E1		5		E1
E2		6		E2
E3		7		E3
E4		8		E4
E5		9		E5
E6		10		E6
E7		11		E7
E8		12		E8
E9		13		E9
E10		14		E10
E11		15		E11
E12		16		E12
E13		17		E13
E14		18		E14
A1		19		A1
A2		20		A2
A3		21		A3
A4		22		A4
A5		23		A5
A6		24		A6
A7		25		A7
A8		26		A8
A9		27		A9
A10		28		A10
		29/PE		
	-X1:15	30/PE		

Function	Objective	Terminal	Objective
Plug-in card holder -X10 System simulation			
		2 a	-R13
		2 c	-P13/Cathode
		4 a	-R14
		4 c	-P14/Cathode
		6 a	-B11/NC
4L+ -X2:5		6 c	+24 V
		8 a	-B11/NO
		8 c	-B10/NC
		10 a	
		10 c	-B10/NO
		12 a	
		12 c	-R10
		14 a	
		14 c	-R11
		16 a	-P18/Anode
		16 c	
		18 a	
		18 c	
		20 a	-P17/Anode
		20 c	
		22 a	-R15
		22 c	
		24 a	-R16
		24 c	
		26 a	-B13:2
		26 c	
		28 a	
		28 c	-B12:2
		30 a	
		30 c	
		32 a	-R12
4L- -X2:11		32 c	0 V

YELLOW
LET Part 2
2026

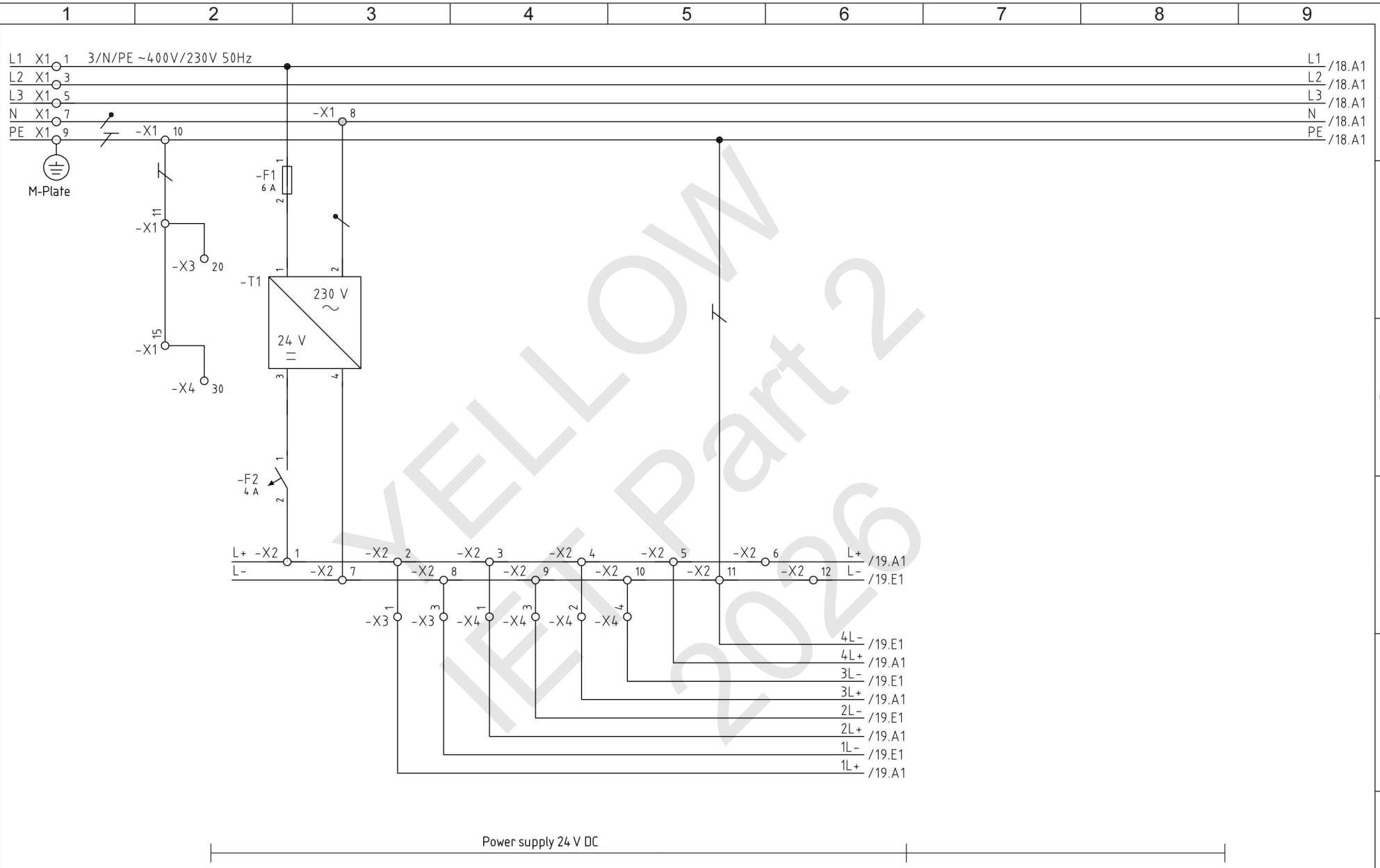

Power supply 24 V DC

1 2 3 4 5 6 7 8 9

/17.A9 L1
/17.A9 L2
/17.A9 L3
/17.A9 N
/17.A9 PE



YELLOW
LET Part 2
2026

A
B
C
D
E
F

A
B
C
D
E
F

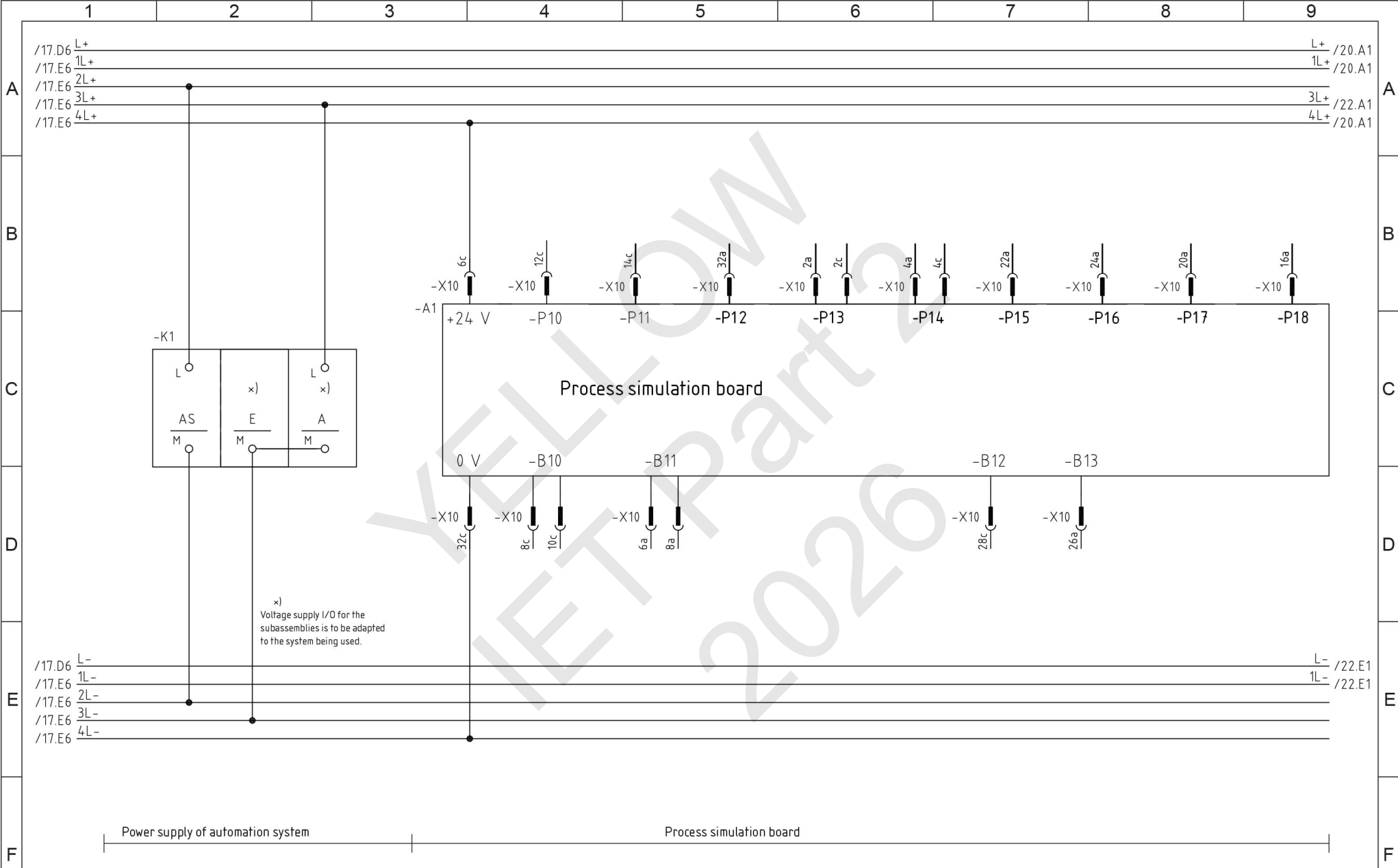

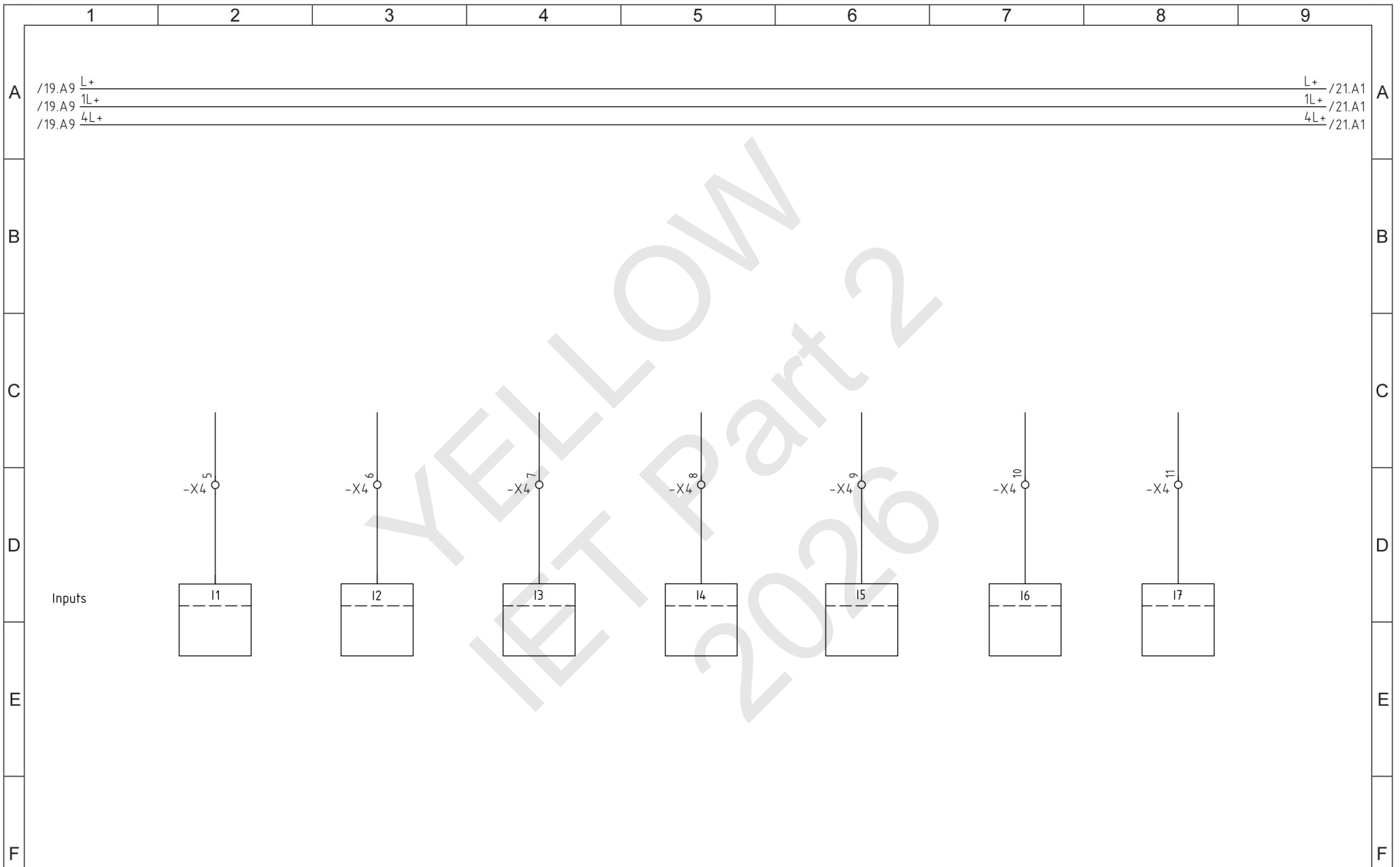

A

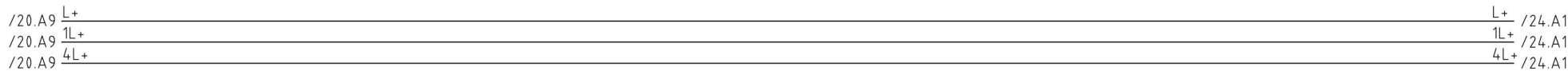

A

B

B

C

C

D

D

E

E

F

F

Inputs

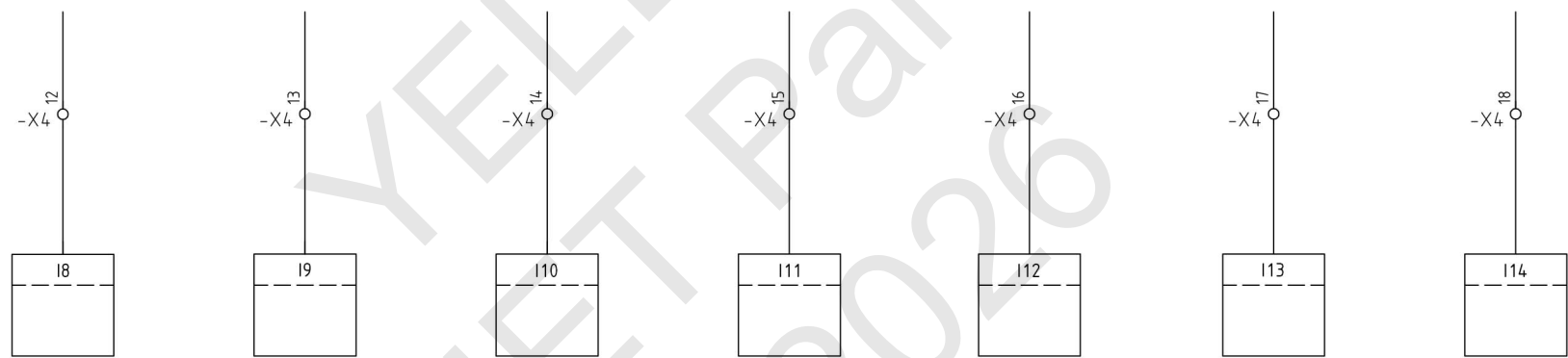

AHK

Final Examination Part 2 - 2026
Industrial Electronics Technician

Work Task
Preparation for the practical tasks
Connection diagram: Input module

First and last name:

Test taker number:

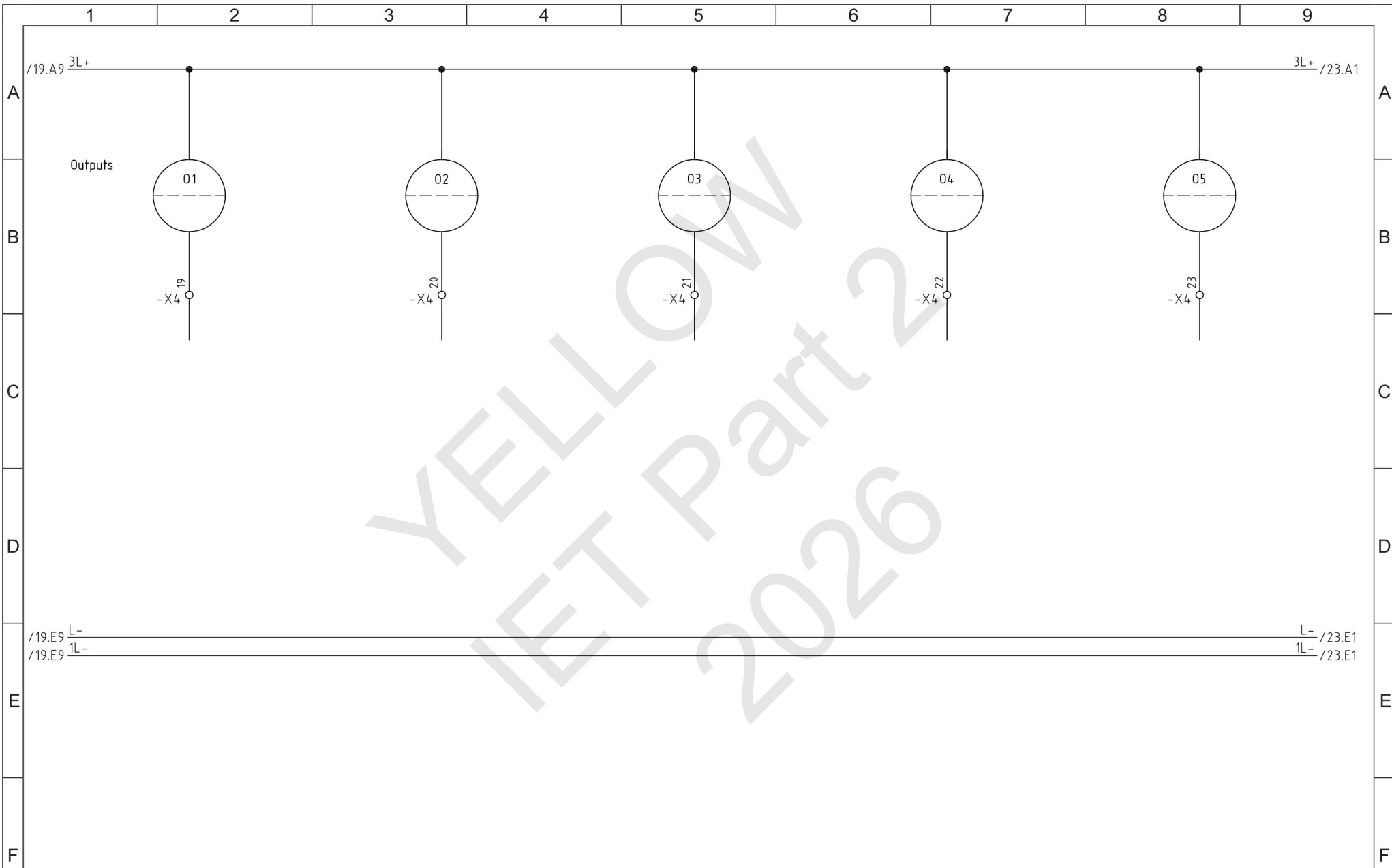

YELLOW
LET Part 2
2026

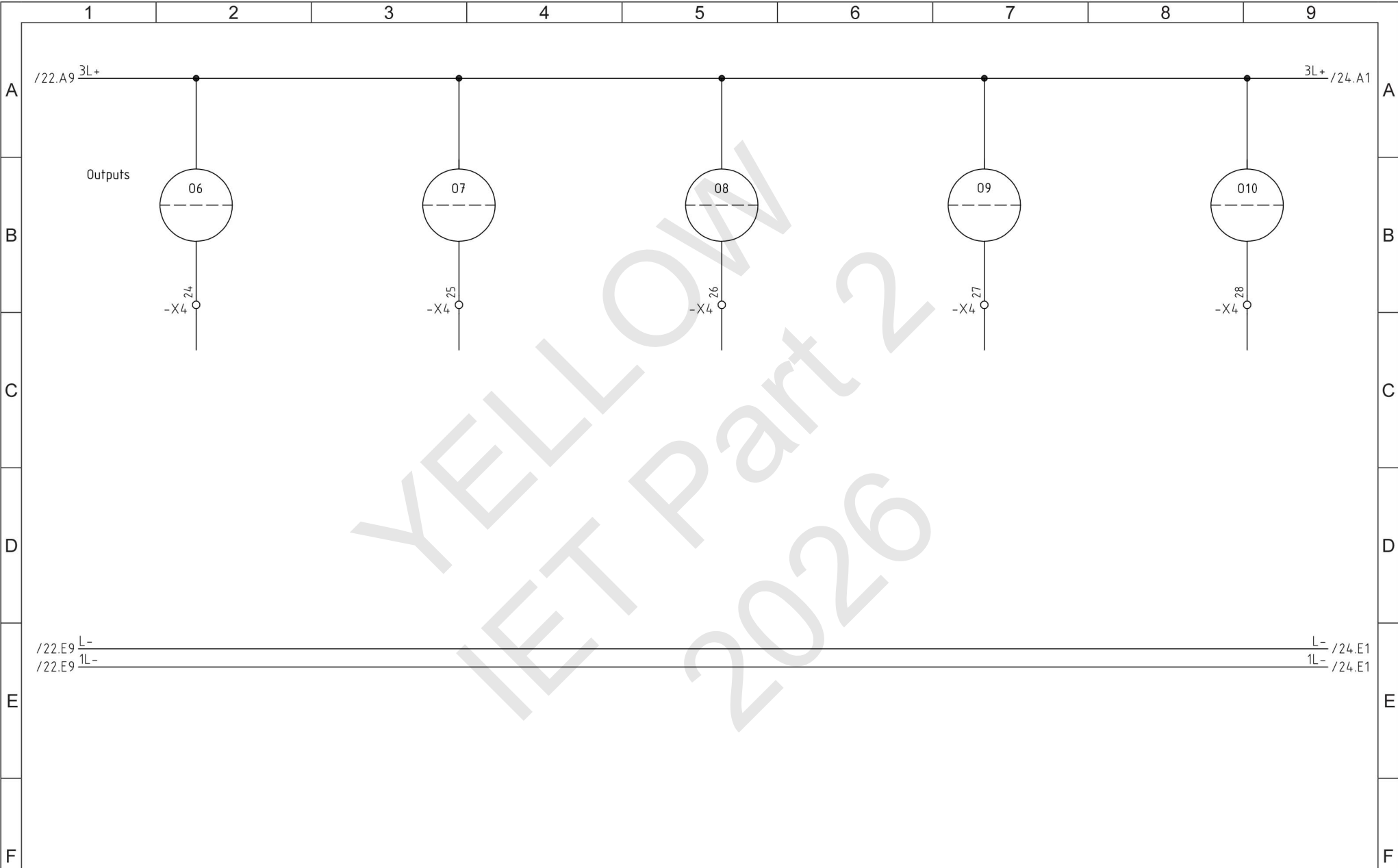

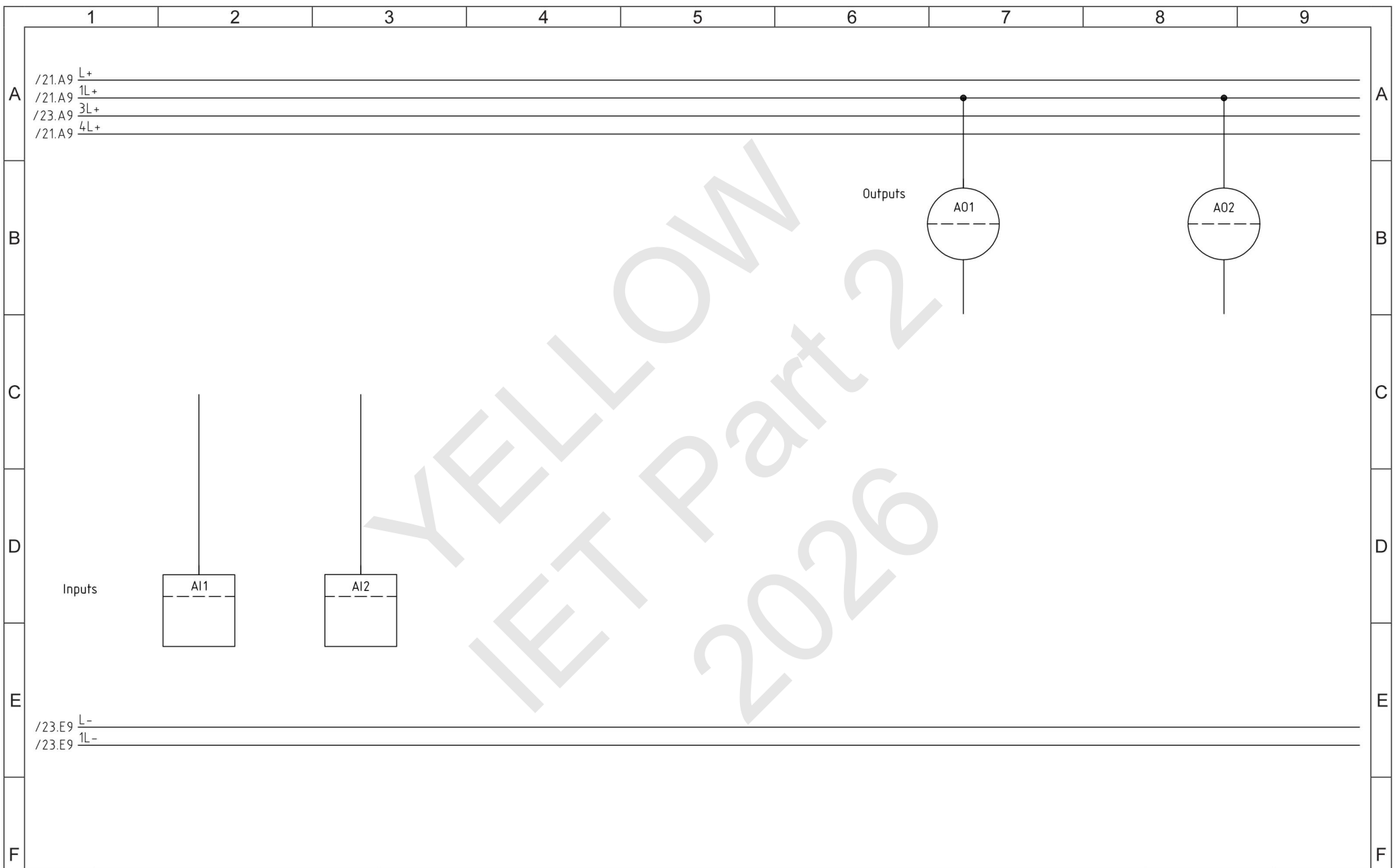

AHK-USA Chicago

Final Examination Part 2 - 2026

PLC
Preparation of the practical task
Tag/Address lists

Industrial Electronics Technician

A company-specific printout of the input and output assignment lists may be printed and brought to the exam instead of using this list.

↓ System related Tags/Addresses are to be entered here.

Inputs	Tag/Address	Equipment identifier	Function – Description and comments
I1			
I2			
I3			
I4			
I5			
I6			
I7			
I8			
I9			
I10			
I11			
I12			
I13			
I14			
Analog inputs:			
1			
2			
Outputs			
O1			
O2			
O3			
O4			
O5			
O6			
O7			
O8			
O9			
O10			
Analog outputs:			
1			
2			

Flag:	Tag/Address	Equipment identifier	Function – Description and comments
1			
2			
3			
4			
5			
6			
7			
8			
9			
10			
11			
12			

Timers:			
1			
2			
3			
4			
5			
6			

Counters:			

System-related Tags/Addresses:			



AHK-USA Chicago

Final Examination Part 2 - 2026

Work Task

**Preparation of the practical task
Programming Documentation**

Industrial Electronics Technician

This blank page can be used for additional handwritten documentation.

Programming documentation

YELLOW
IET Part 2
2026



<h1>AHK-USA Chicago</h1>	
<h2>Final Examination Part 2 - 2026</h2>	
Work Task Preparation of the practical task Commissioning Protocol	Industrial Electronics Technician

General Information:

The completed, functional electrical system must be inspected in accordance with DIN VDE 0100-600 or company standard. To document the test, this commissioning protocol or a company-specific commissioning protocol document can be used. The commissioning protocol must be brought on the day of the test.

System:	Tester:
---------	---------

Test after:	<input type="checkbox"/> New build	<input type="checkbox"/> Expansion	<input type="checkbox"/> Modification	<input type="checkbox"/> Repair
-------------	------------------------------------	------------------------------------	---------------------------------------	---------------------------------

Inspection			
<ul style="list-style-type: none">• Complete circuit documentation		<input type="checkbox"/> Ok	<input type="checkbox"/> Not OK
<ul style="list-style-type: none">– Completion of all documents			
<ul style="list-style-type: none">• Operating equipment		<input type="checkbox"/> Ok	<input type="checkbox"/> Not OK
<ul style="list-style-type: none">– Correct selection, no damage, equipment marking			
<ul style="list-style-type: none">• Line connections		<input type="checkbox"/> Ok	<input type="checkbox"/> Not OK
<ul style="list-style-type: none">– Insulation, removing cable sheaths, fastening			
<ul style="list-style-type: none">• Selection of lines and routing		<input type="checkbox"/> Ok	<input type="checkbox"/> Not OK
<ul style="list-style-type: none">– Line type, cross section, routing, marking			
<ul style="list-style-type: none">• Safety measures against direct contact		<input type="checkbox"/> Ok	<input type="checkbox"/> Not OK
<ul style="list-style-type: none">– Protection against touching with fingers, covers			
<ul style="list-style-type: none">• Overcurrent protective devices		<input type="checkbox"/> Ok	<input type="checkbox"/> Not OK
<ul style="list-style-type: none">– Selection, settings			
<ul style="list-style-type: none">• No detectable flaws at time of test		<input type="checkbox"/> True	<input type="checkbox"/> False

Measuring/Testing

Continuity of protective earth wire	measured value: _____	<input type="checkbox"/> Ok	<input type="checkbox"/> Not OK
Insulation measurement points			
– All active conductors to all active conductors and to PE			

Measuring points terminals	Measured value

Measuring points terminals	Measured value

		<input type="checkbox"/> Ok	<input type="checkbox"/> Not OK
<ul style="list-style-type: none">• RCD/Circuit breaker		<input type="checkbox"/> Ok	<input type="checkbox"/> Not OK
<ul style="list-style-type: none">– Contact voltage			
<ul style="list-style-type: none">• Activation time in the circuit with	Measured value: _____	<input type="checkbox"/> Ok	<input type="checkbox"/> Not OK
<ul style="list-style-type: none">• RCD rotary field test			
<ul style="list-style-type: none">– (field rotating clockwise)		<input type="checkbox"/> Ok	<input type="checkbox"/> Not OK

Testing

<ul style="list-style-type: none">• Contact voltage		<input type="checkbox"/> Ok	<input type="checkbox"/> Not OK
<ul style="list-style-type: none">– Function in accordance with circuit diagram			
<ul style="list-style-type: none">• RCD function		<input type="checkbox"/> Ok	<input type="checkbox"/> Not OK
<ul style="list-style-type: none">– Activating test button			

<input type="checkbox"/> The electrical system corresponds to the recognized regulations of electrical standards and has no faults
--

Date	Apprentice Signature	Trainer signature
------	----------------------	-------------------

