

Mechatronics Technician

Exam Preparation Documentation

Part 2 Phase 2

2026

Test Taker first and last name:

Test Taker number:

Test Taker company:



German American
Chambers of Commerce
Deutsch-Amerikanische
Handelskammern

**German American Chamber of Commerce
of the Midwest, Inc.**

150 North Michigan Avenue, 35th Floor
Chicago, Illinois 60601

Phone: +1 (312) 644-2662 | Fax: +1 (312) 644-0738
www.gaccmidwest.org

AHK-USA Chicago Final Examination Part 2, PHASE 2- 2026	
Preparation for the Practical task General information	Mechatronics Technician

General information**DO NOT DO PHASE 2 until you have completed PHASE 1.**

Your starting point or foundation for this subassembly is what you should have already assembled according to your initial “yellow” PHASE 1 preparation documentation. NOW you will make modifications by completing the PHASE 2 of the preparation. On the day of examination, the test taker must bring in the mechatronics subsystem assembled as described in this PHASE 2 packet. Do not do more modifications than is described in the “yellow PHASE 1” and “yellow PHASE 2” packet.

To your completed PHASE 1, only add to the mechatronics assembly as specified in numbers 1-6 on the “Preparation for the practical assignment – work assignment- Task description” found in the following documents. Do not add more than what is explicitly stated in steps 1-6. As part of step 6 you are to draw these additions or modifications into the “yellow” drawings and schematics that are included in the PHASE 1 packet. Changes should be noted and initialed - including the date the change was made (i.e.GS 01/APR/22)- on schematics and blueprints!

All equipment should also be tested for functionality prior to the exam. Read all steps before starting. Anything you may have added or connected to test a function but is not listed in steps 1-6 should be removed before the day of the examination.

The following “4 phases” are meant to guide you through the proper set up and mechatronics testing process:

- I Information phase
- II Planning phase
- III Execution phase
- IV Check phase

Consider each as you create and test a modification (work assignment steps 1-6) according to the attached documentation “Preparation for the practical assignment - work assignment -Task description”. After set up you will submit relevant documentation for evaluation on exam day.

Complete all “4 phases” as you prepare the system described in the attached documentation. **Take notes and document your steps!** You must bring in your preparation work and supporting materials as described below to demonstrate your ability to properly prepare and set up a mechatronics system.

Use the diagrams, drawings and schematics already provided from your “yellow” preparation booklet for additions/expansions. As part of step 6, draft or add to drawings, schematics and diagrams, to show what was completed in steps 1-6. Use proper symbols in your drawings. Changes should be noted and initialed - including the date the change was made (i.e.GS 01/APR/22)- on schematics and blueprints! You will bring this to the exam for review and further modification.

Write your first and last name and your test taker number on all documents, even your internal documents and those you have created yourself for the specific assignment, **and place in a folder to bring to the examination.**

The working mechatronics system and your folder/binder containing your documents and other self-created documentation must be presented on the day of the examination. Please do not include photos.



Any further required modification work will be performed during the examination time! Unused components listed in the standard material staging list in your “yellow” documentation that are not required to complete the system described below are to be brought in on the day of the examination.

I Information phase

In the information phase, you should demonstrate the ability to do the following:

- Read through the documents and collect information.
- Use the documents and collected information to create the work assignment while observing the applicable standards and regulations as well as the requirements set forth for the client (i.e. certification, documentation).

I Planning phase

In the planning phase, you should be able to demonstrate the following:

- Create a work plan from the requirements in the assignment while taking the given information into consideration.
- Completely and properly draft and supplement drawings (circuit diagrams, terminal connection diagrams, flow charts, ...) and documentation (programs, parameter lists, ...).
- Create test and measurement reports for the component inspection and commissioning reports.

II Implementation phase

In the implementation phase, you should be able to demonstrate the following:

- The ability to complete the assignment according to the workflow you created.
- **Prepare the mechatronics assembly according to numbers 1-6 on the “Preparation for the practical assignment – work assignment- Task description.”**
- The ability to visually check work and make corrections.

III Check phase

In the check phase, you should be able to demonstrate the following:

- Check pre-mounted assemblies according to your test report, document and evaluate the results.
- Perform the safety check, commissioning and functional check according to test reports; document and evaluate the results.

IV Submission

Mark all documents with your first and last name as well as your test taker number.

Put what you believe to be the most important examination documents together and place these in a logical order in a folder to bring to the examination. Prepare a table of contents and a cover sheet for all of your documentation from your preparation to present to the exam board. Check the work performed and correct any mistakes. Please do not include photos in your folder.

Examination day (executing the assignment)

On examination day, plan to bring the following to the testing center:

- The remaining material from the material provisioning lists from Phase 1
- Consumables, auxiliary equipment, test material and tools as per the standard material staging list documents as well as the necessary equipment to modify the control program (documentation can be handwritten)
- The functioning axis model as well as the functioning controller in accordance with the preparation assignment
- Yellow preparation documentation and other informational and planning documentation in an organized binder. No photos please.

AHK-USA Chicago

Final Examination Part 2, PHASE 2- 2026

**Preparation for the Practical task
– work assignment
Task description**

Mechatronics Technician

1 General information

You have been tasked with retrofitting the system. You have been assigned to implement the requested information. Of course, in doing so you must adhere to and take into account standards and regulations.

2 Description of the preparation task (Steps 1-7)

The system should be set up so that there are 4 possible storage positions on the tabletop for the cubes when pushed out of the magazine that is on the carriage slide. The inductive sensors -BG11 (left) and -BG13 (right) limit the travel of the carriage slide. Any of the storage positions can be approached using the positioning plate and the -BG12 sensor. The four storages positions are indicated with light -PF8.

Automatic mode can only start when it is in home position. Home position is indicated by -BG11. – BG21, and -BG51. Home position can only be reached in jog mode. The “zero” (“C1=0”) position is set by -BG11 in the left end position.

The current system should deliver a cube to storage position 2 and storage position 3. The magazine is loaded with a max of 2 cubes.

In addition to the drawings already received, the following points must be observed for the retrofit then completed and added to/drawn into your “yellow” Phase 1 drawings in your binder. Use the sheet included in this packet to write out your work plan for completing these steps and include it in your binder to be reviewed prior to your examination start.

1. Wire in the reflective light barrier -BG52 to detect the storage positions on input I21. The reflective light barrier will generate a “high” signal when the tabletop is empty. -PF33 is activated through O09 to signal “tabletop empty”. Be sure to modify the workflow according to GRAFCET in your Phase 1 documentation to show this new functionality. The addition of -PF33 you will find in the schematics provided in Phase 2.
2. Plan and implement the mounting of the reflective light barrier in accordance with operational requirements. The reflective light barrier should detect cubes placed on the tabletop (from storage position 1 to storage position 4). You may need to tape over your reflector mirror slightly in order to detect the small cubes.
3. The cubes should be placed on the tabletop in a targeted manner therefore two pockets must be milled in storage position 2 and 3 with the dimensions of 35 x 35 x 3.5mm. Round the corners of the pockets with a radius of 3mm. You will find the drawings for this modification in Phase 2.
4. Wire in the PG/PC receptacle -XD11, the RCD or GFCI -FB1, and circuit breaker -FC1
5. On your own commissioning sheet, document all measured values for each step of commissioning to check for safety before and after testing for function.
6. Put the system into operation. Perform tests to check the programming and functionality of your system. Home position is the left end position.
7. In your binder, document all necessary changes for the Phase 2 retrofit. Do not forget about the I/O lists and any other element of the Yellow Phase 1 documentation that must be changed to reflect your new system status including electrical and mechanical drawings (Changes should be noted and initialed - including the date the change was made (i.e.GS 01/APR/22)- on schematics and blueprints!)

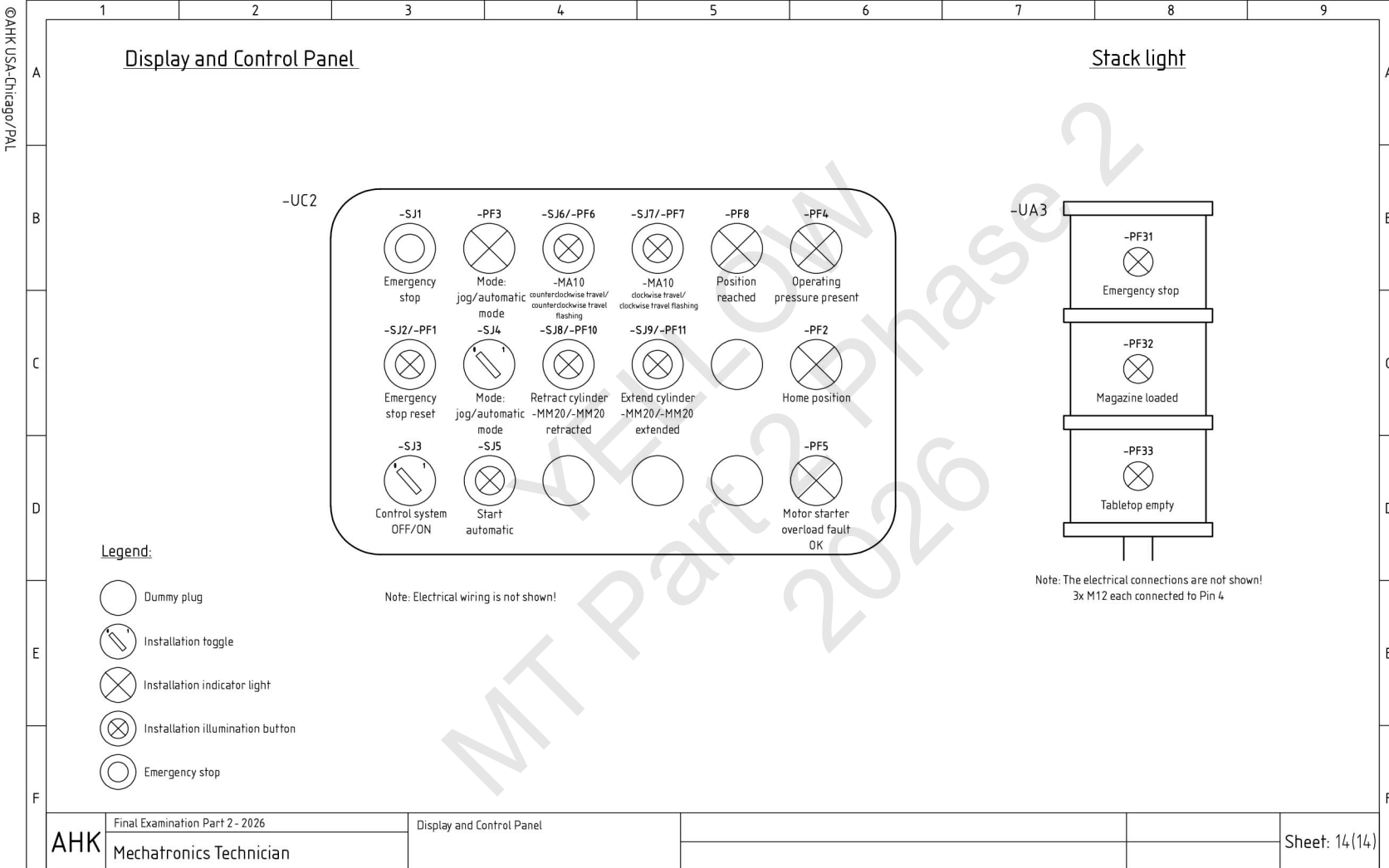

©AHK USA-Chicago/PAL

Task
Preparation for the practical exam assignment
Mechanical modifications

Mechatronics Technician

Table top

S235JR+C

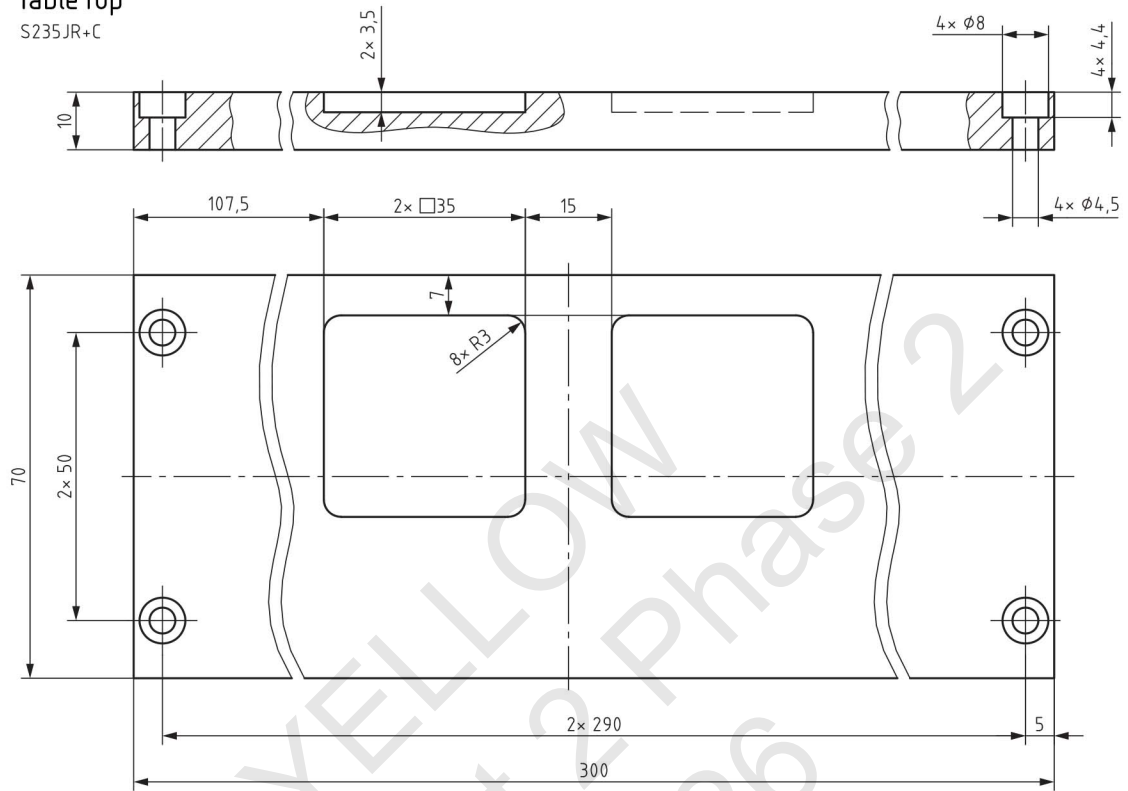

Task
Preparation for the practical exam assignment
Mechanical modifications

Mechatronics Technician

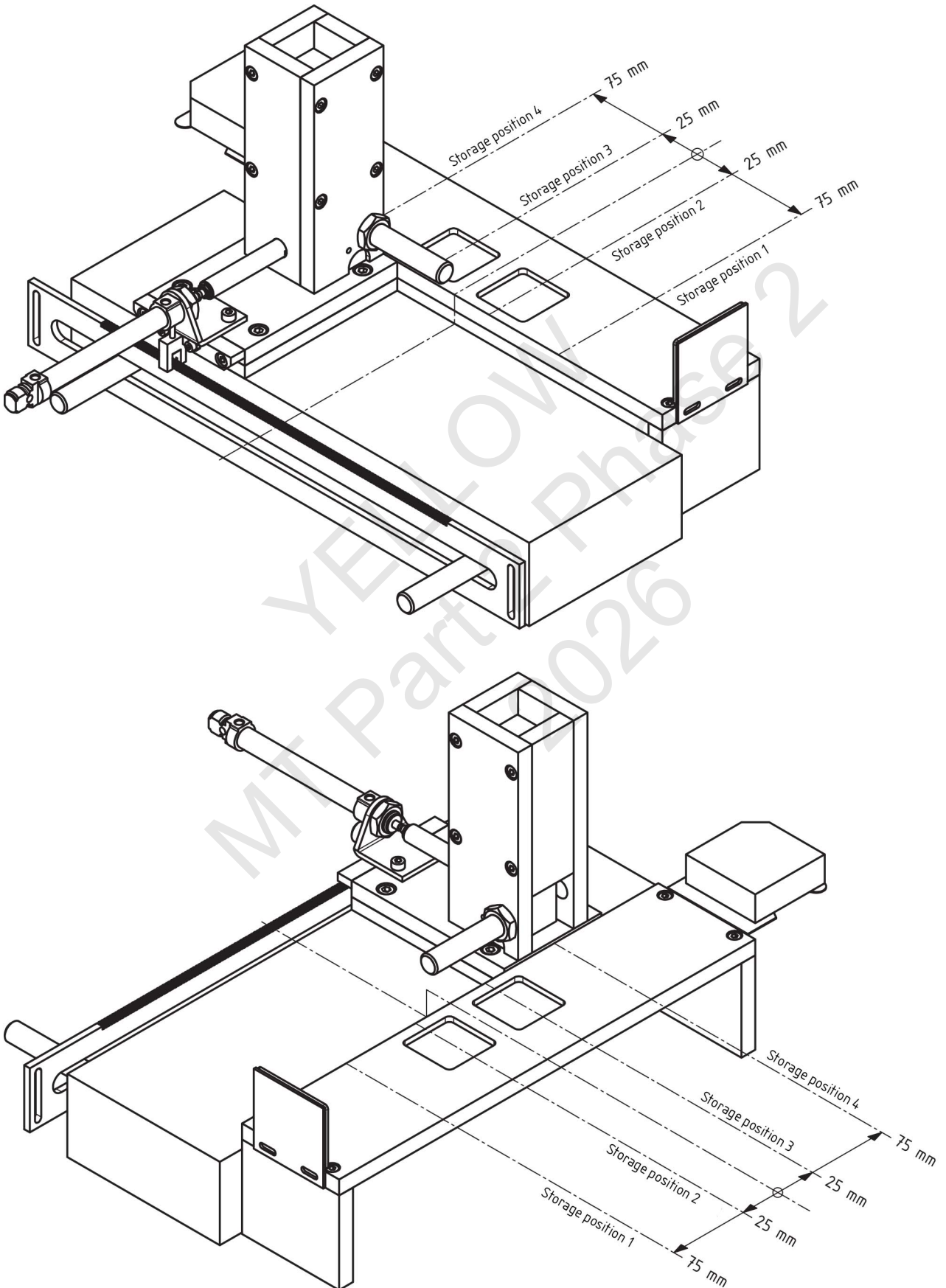

AHK-USA Chicago

Final Examination Part 2, PHASE 2 - 2026

**Preparation of the practical
assignment
Planning – workflow plan**

Mechatronics Technician

When preparing for the practical assignment, it is advisable to plan the work steps in a logical order. These steps along with your other preparation documentation are to be presented to the exam board in an organized folder on the day of the practical exam. Add pages if necessary.

Outline your work steps with key words or short sentences below:

YELLOW
MT Part 2 Phase 2
2026